



UPA88T Walk-Behind Plate Compactor

Urethane Pad Installation Kit Instructions

The following instructions are intended to assist the user in installing the UPA88T Kit, Urethane Pad Attachment to the MultiQuip MVC88VTH/VTHW Series plate compactors. The UPA88T is designed for compacting paving stones and decorative brick. The pad prevents damage to the stone as the plate passes over the surface. It is not intended for soil or backfill compaction. Please read the instructions before assembling.

REQUIRED TOOLS

- 3/8" Ratchet/Socket Set

PARTS

Verify that all parts are accounted for. See Figure 1 and Table 1.

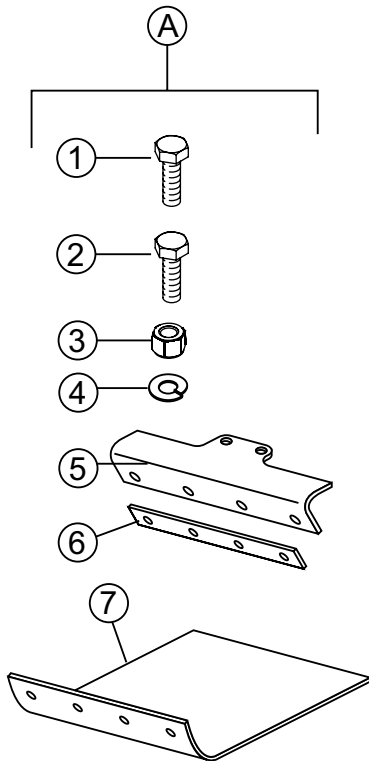

Figure 1. Kit Parts

Table 1. Kit Parts

Item No.	Part No.	Description	Qty.	Remarks
A	UPA88T	Kit, Urethane Plate Attachment*	1	Includes Items 1-7
1	012012030	Bolt 12x30, GRD. 12.9	2	
2	011208035	Bolt 8x35	4	
3	022710809	Nylon Nut M8	4	
4	030212300	Washer, Lock M12	2	
5	416352080	Hanger, Urethane Plate	1	
6	416352090	Plate, Urethane	1	
7	PADUPA88	Urethane Pad	1	

WORK SAFELY!

Only a **qualified service technician** with proper training should perform this installation. Follow all shop safety rules when performing this installation.

URETHANE PLATE INSTALLATION

1. Using a 3/8" ratchet and 24 mm socket, remove and **discard** the 2 eccentric mounting bolts and lock washers (Figure 2) at the front of the plate compactor.

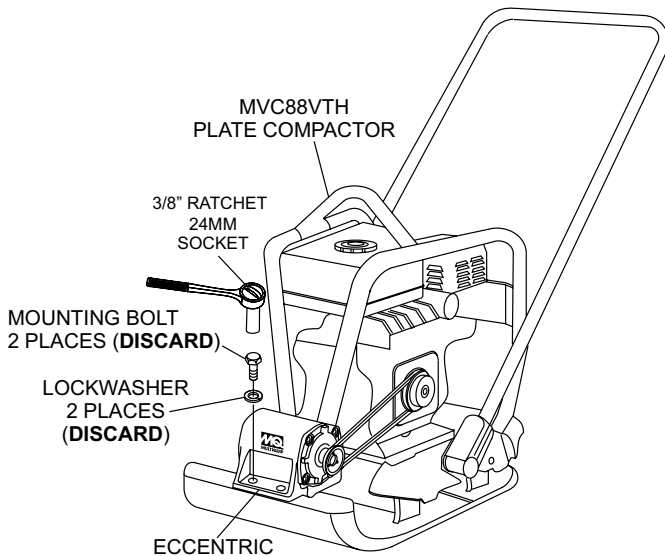

Figure 2. Eccentric Mounting Bolts Removal

2. Align the 4 holes on the plate (item 6) with the 4 holes on the front of the urethane pad (item 7).
3. Insert the four 8x35 bolts (item 2) through the plate (item 6) and urethane pad (item 7) mounting holes.
4. Attach the plate and urethane pad (items 6 and 7) to the urethane plate hanger (item 5) by inserting the 4 bolts sticking out from the plate/urethane pad into the hanger urethane plate mounting holes.

5. To finish securing the plate and urethane pad to the urethane plate hanger, use a 3/8" ratchet and 13 mm socket and tighten the four 8x35 bolts (item 2) to 25 ft-lb (34 N·m). Bolts are secured using the 4 nylon nuts (item 3).
6. Lay the assembled urethane pad flat on the ground and place the plate compactor on top of the pad with the urethane plate hanger about 2 to 3 inches from the front of the compactor's base plate.
7. Slide in the assembled urethane pad towards the compactor aligning the 2 holes on the urethane plate hanger with the the 2 holes on the eccentric.
8. Apply a small amount of Loctite 242 or equivalent to the two 12x30 (item 1) bolt threads that secure the urethane hanger plate to the frame.
9. Next, using a 3/8" ratchet and 19 mm socket, insert the two 12x30 bolts (item 1) with 2 lock washers (item 4) into the urethane plate hanger mounting holes and then into the two holes on the eccentric plate. Torque screws to 108 ft-lb (146 N·m) **DO NOT OVERTIGHTEN.**

NOTICE

DO NOT apply an **excessive amount** of Loctite to the bolt threads. Too much thread locking compound could lead to improper bolt torquing.

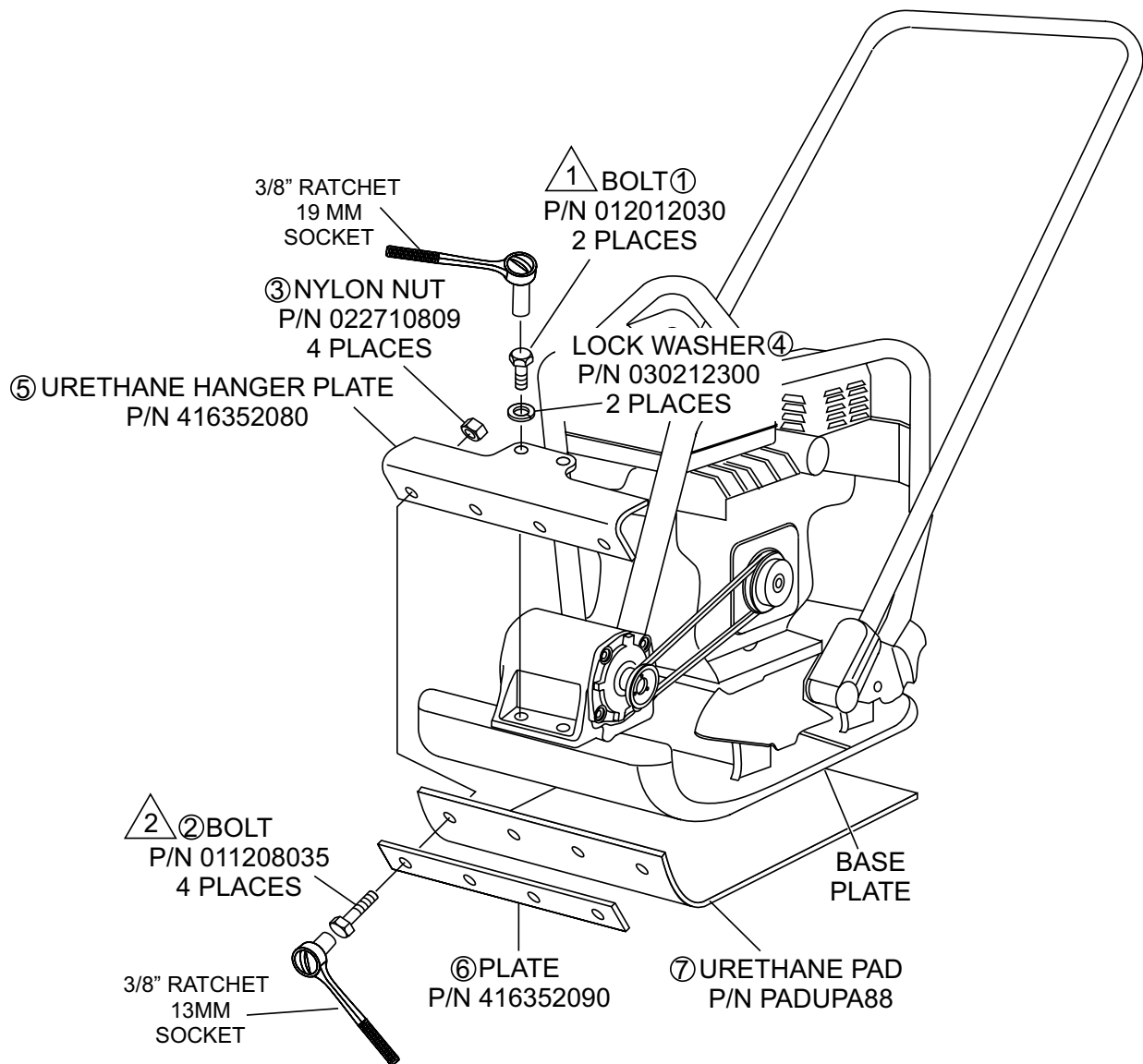

NOTES:

① TORQUE TO 108 FT-LB (146 N·m)

② TORQUE TO 25 FT-LB (34 N·m)

Figure 3. Location of Parts and Components



UPA88T Walk-Behind Plate Compactor

Urethane Plate Installation Kit Instructions

HERE'S HOW TO GET HELP

PLEASE HAVE THE MODEL AND SERIAL
NUMBER ON-HAND WHEN CALLING

UNITED STATES

Multiquip Corporate Office

18910 Wilmington Ave. Tel. (800) 421-1244
Carson, CA 90746 Fax (310) 537-3927
Contact: mq@multiquip.com

Service Department

800-421-1244 Fax: 310-537-4259
310-537-3700

Technical Assistance

800-478-1244 Fax: 310-943-2238

MQ Parts Department

800-427-1244 Fax: 800-672-7877
310-537-3700 Fax: 310-637-3284

Warranty Department

800-421-1244 Fax: 310-943-2249
310-537-3700

CANADA

Multiquip

4110 Industriel Boul. Tel: (450) 625-2244
Laval, Quebec, Canada H7L 6V3 Tel: (877) 963-4411
Contact: jmartin@multiquip.com Fax: (450) 625-8664

UNITED KINGDOM

Multiquip (UK) Limited Head Office

Unit 2, Northpoint Industrial Estate, Tel: 0161 339 2223
Globe Lane, Fax: 0161 339 3226
Dukinfield, Cheshire SK16 4UJ
Contact: sales@multiquip.co.uk

© COPYRIGHT 2015, MULTIQUIP INC.

Multiquip Inc and the MQ logo are registered trademarks of Multiquip Inc. and may not be used, reproduced, or altered without written permission. All other trademarks are the property of their respective owners and used with permission.

The information and specifications included in this publication were in effect at the time of approval for printing. Illustrations, descriptions, references and technical data contained in this document are for guidance only and may not be considered as binding. Multiquip Inc. reserves the right to discontinue or change specifications, design or the information published in this publication at any time without notice and without incurring any obligations.

Your Local Dealer is:

