



# MVH308DZ/MVH408DZ/MVH508DZ Reversible Plate Compactor COMPAS II Compaction Analyzing System Installation Instructions

The following instructions are intended to assist the user in the installation of the COMPAS II Compaction Analyzing System for use on the MVH308DZ, MVH408DZ, and MVH508DZ reversible plate compactors. Please read all assembly instructions before installing the system kit.

## PARTS

Verify that all parts are accounted for. See Figure 1 and Table 1.

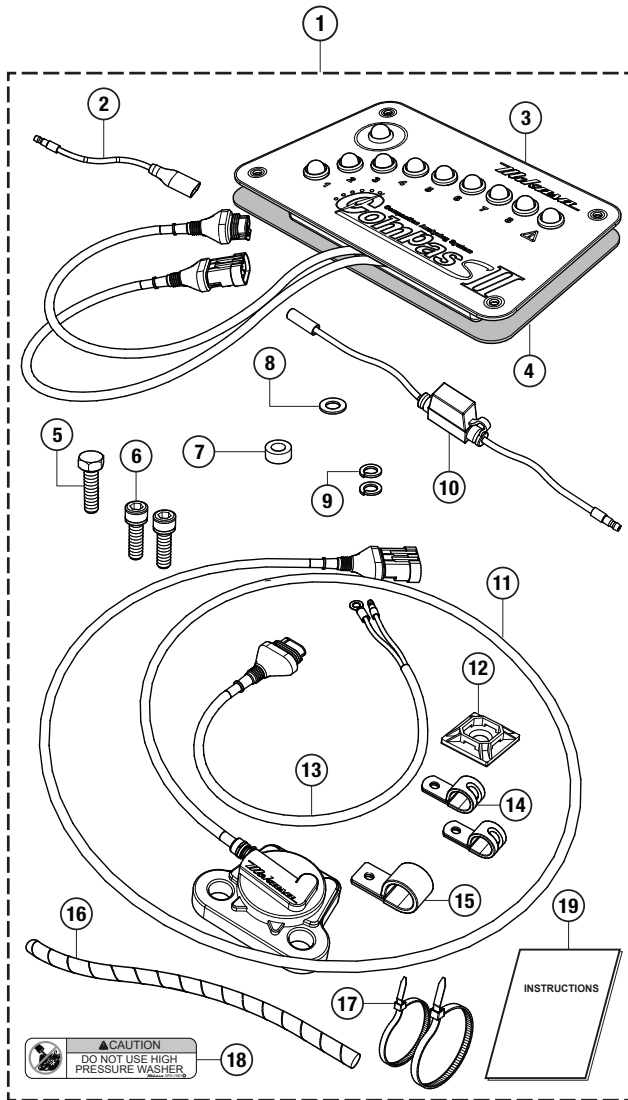

Figure 1. COMPAS II Compaction Analyzing System Kit

Table 1. COMPAS II Compaction Analyzing System Kit

Item	Part No.	Description	Qty.	Remarks
1	CPAS308DZ	Kit, COMPAS II Compaction Analyzing System	1	Includes items 2–19
1	CPAS408DZ	Kit, COMPAS II Compaction Analyzing System	1	Includes items 2–19
1	CPAS508DZ	Kit, COMPAS II Compaction Analyzing System	1	Includes items 2–19
2	515450380	Lead Wire, Yellow	1	
3	467310010	Compaction Sensor Panel, MVH-308	1	CPAS308DZ only
3	468310010	Compaction Sensor Panel, MVH-408	1	CPAS408DZ only
3	469310010	Compaction Sensor Panel, MVH-508	1	CPAS508DZ only
4	464350510	Sensor Panel Backing	1	
5	001221035	Hex Head Bolt, 10 × 35	1	
6	001521030	Socket Head Bolt, 10 × 30	2	
7	740426290	Spacer, 10.5 × 22 × 10	1	
8	031110160	Flat Washer, M10	1	
9	030210250	Lock Washer, M10	3	
10	467352850	Fuse Holder	1	
11	467352040	Assy, Acceleration Sensor	1	Includes item 16
12	955409080	Cable Tie Mount, Self-Adhesive	1	
13	467352830	Wire Harness	1	
14	959408920	Cable Clamp, Φ8 for M8	2	
15	959408930	Cable Clamp, Φ15 for M6	1	
16	959021812	Spiral Tube	1	
17	506010070	Cable Tie	7	
18	920112220	Decal, High Pressure Wash Prohibited, English	1	
19	N/A	Instructions, COMPAS II Installation	1	

## REQUIRED TOOLS

- 10 mm, 13 mm, 17 mm, and 21 mm Socket or Wrench
- 13 mm Offset Wrench
- 4 mm, 5 mm, 6 mm, and 8 mm Hex Wrench
- Cable Tie Cutters
- Needle-Nose Pliers
- Loctite® 243™ and 263™ Thread Sealant

## WORK SAFELY!

Only a **qualified service technician** with proper training should perform this installation. Follow all shop safety rules when performing this installation.

## COMPACTOR SAFETY

### DANGER

- **NEVER** operate the equipment in an explosive atmosphere or near combustible materials. An explosion or fire may result, causing **severe bodily harm or even death**.



### WARNING

- **NEVER** disconnect any emergency or safety devices. These devices are intended for operator safety. Disconnection of these devices can cause **severe injury, bodily harm or even death**. Disconnection of any of these devices will void all warranties.

### CAUTION

- **NEVER** lubricate components or attempt service on a running machine.

## BATTERY SAFETY

### DANGER

- **DO NOT** drop the battery. There is a possibility that the battery will **explode**.
- **DO NOT** expose the battery to open flames, sparks, cigarettes, etc. The battery contains combustible gases and liquids. If these gases and liquids come into contact with a flame or spark, **an explosion can occur**.



### WARNING

- **ALWAYS** wear safety glasses when handling the battery to avoid eye irritation. The battery contains acids that can cause **serious injury to the eyes and skin**.
- **ALWAYS** wear well-insulated gloves when handling the battery.
- If battery liquid (dilute sulfuric acid) comes into contact with clothing or skin, rinse clothing or skin **immediately** with plenty of water.
- If battery liquid (dilute sulfuric acid) comes into contact with eyes, rinse eyes **immediately** with plenty of water and seek medical attention from the nearest hospital or doctor.



### CAUTION

- **ALWAYS** disconnect the **negative** battery cable before performing service on the equipment.
- **ALWAYS** keep battery cables in good working condition. Repair or replace all worn cables.

## TRANSPORTING SAFETY

### CAUTION

- **NEVER** allow any person or animal to stand underneath the equipment while it is being lifted.

### NOTICE

- Before lifting, **ALWAYS** make sure equipment parts (hook and vibration insulator) are undamaged, and no screws are loose or missing.
- **ALWAYS** make sure the lifting bail (hook) of the equipment has been properly secured to the crane or other lifting device.
- **NEVER** lift the equipment while the engine is **running**.
- **ALWAYS** tighten the fuel tank cap securely and close the fuel cock to prevent fuel from spilling when lifting or transporting the equipment.
- **ALWAYS** use adequate lifting cable (wire or rope) of sufficient strength.
- **ALWAYS** use a single-point suspension hook and lift the equipment straight upward.
- **NEVER** lift the equipment to unnecessary heights.

## PREPARATION

1. Make sure the plate compactor is turned **OFF** and the engine is cool.
2. Place the plate compactor in an area free of dirt and debris, and make sure it is on secure, level ground. If possible, lift the compactor a few feet off the ground onto a flat, secure surface for easier access.

## BATTERY DISCONNECTION AND REMOVAL

1. Release the two latches at the top of the rear cover (Figure 2), then pull the rear cover downward to open.

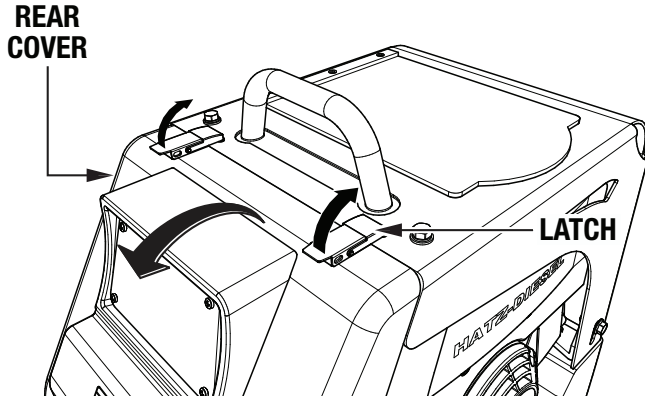

Figure 2. Open Rear Cover

2. Loosen the four 8 × 25 mm bolts securing the air cleaner stay (Figure 3) to the frame.

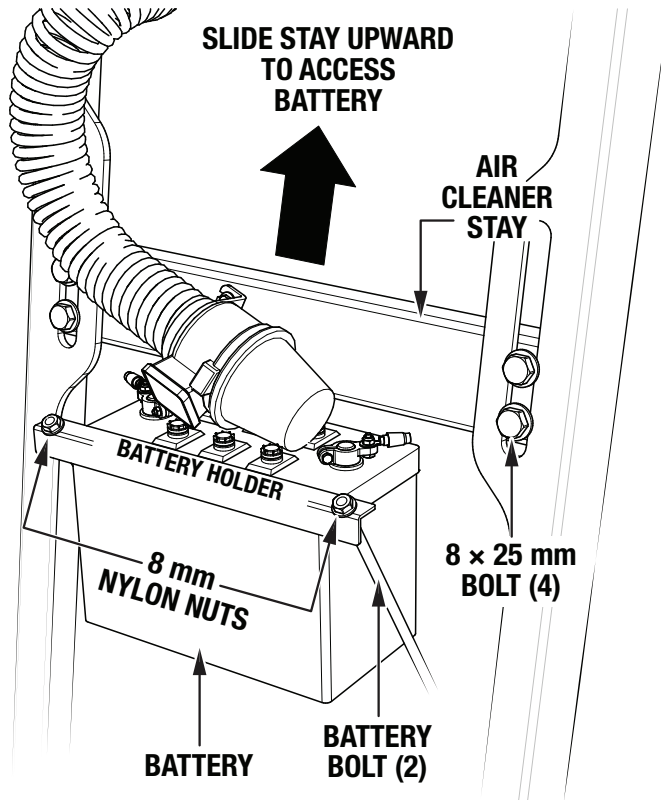

Figure 3. Battery Access

3. Slide the air cleaner stay upward to access the battery, then tighten the four 8 × 25 mm bolts to secure the stay in place (Figure 3).
4. Remove the two 8 mm nylon nuts from the battery bolts securing the battery holder to the battery (Figure 3). Remove the battery holder and set the holder and fasteners aside.

5. Disconnect the negative (**BLACK**) battery cable, then disconnect the positive (**RED**) battery cable (Figure 4).

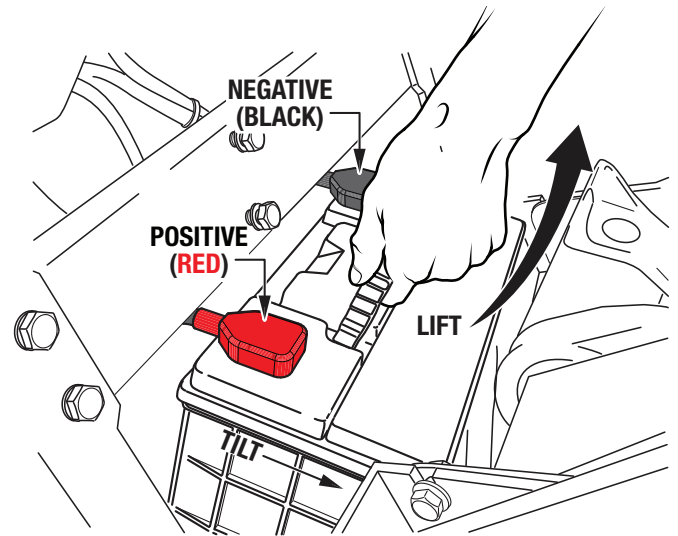

Figure 4. Battery Removal

6. Tilt the battery backward and lift up on the handle to remove (Figure 4). **MAKE SURE** the battery terminals **DO NOT** touch the frame during removal.

## ACCELERATION SENSOR INSTALLATION

1. Remove and discard the **top two** 10 mm bolts, lock washers, and flat washers securing the bearing cover to the vibrator (Figure 5). Leave the existing cable clamp on the hydraulic hose as shown.

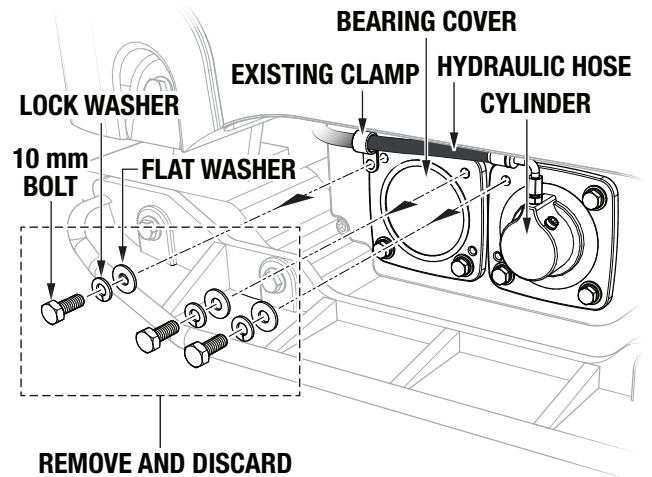
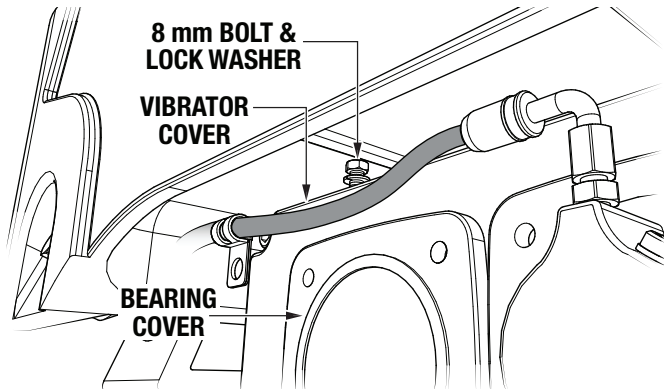

Figure 5. Bolt Removal  
(Bearing Cover and Cylinder)

2. Remove and discard the **top left** 10 mm bolt, lock washer, and flat washer securing the cylinder to the vibrator (Figure 5).

- Using a 13 mm offset wrench, remove one 8 mm bolt and lock washer securing the vibrator cover to the vibrator (Figure 6). The bolt and washer are located just above the bearing cover to the left. Retain the bolt and lock washer for later.



**Figure 6. Bolt Removal (Vibrator Cover)**

- Place a small cable clamp (P/N 959408920) onto the spiral tube (P/N 959021812) near the sensor end of the acceleration sensor assembly (P/N 467352040). See Figure 7.

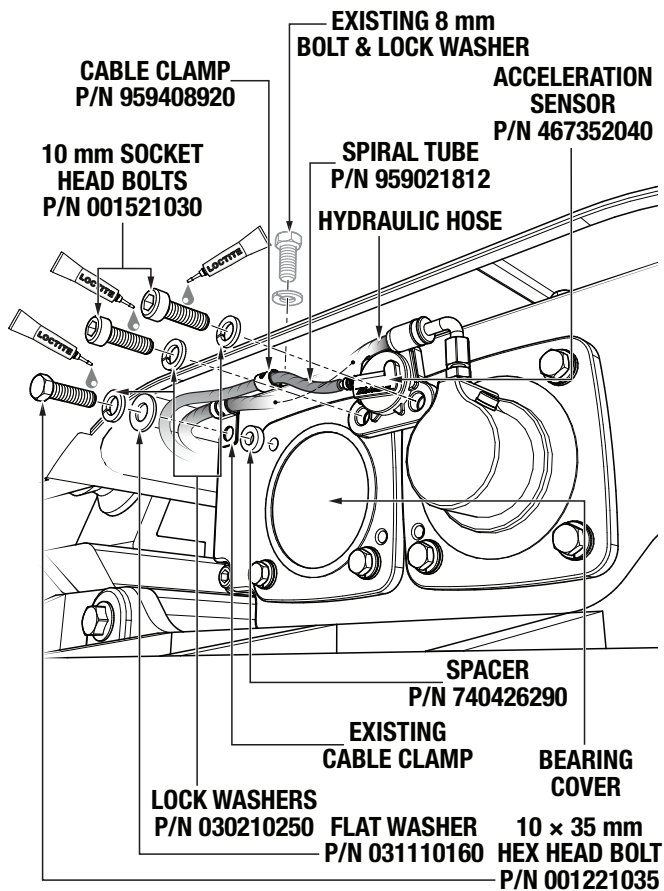

**Figure 7. Acceleration Sensor Installation**

- Insert the existing 8 mm bolt that was removed earlier through the cable clamp (P/N 959408920) and existing lock washer. Reinstall the bolt at its original location and tighten securely. See Figure 7.
- Apply Loctite® 243™ to the threads on the two 10 mm socket head bolts (P/N 001521030). See Figure 7.
- Secure the acceleration sensor (P/N 467352040) to the vibrator with the two 10 mm socket head bolts (P/N 001521030) and lock washers (P/N 030210250). Torque the bolts to 54.2 ft-lb (73.6 N·m). See Figure 7.
- Apply Loctite® 243™ to the threads on the 10 × 35 mm hex head bolt (P/N 001221035). See Figure 7.
- Insert the 10 × 35 mm hex head bolt (P/N 001221035) through a lock washer (P/N 030210250), the flat washer (P/N 031110160), the existing cable clamp on the hydraulic hose, and the spacer (P/N 740426290). See Figure 7.
- Secure the hydraulic hose to the bearing cover with the 10 × 35 mm hex head bolt (P/N 001221035). Torque the bolt to 54.2 ft-lb (73.6 N·m). See Figure 7.
- Secure the acceleration sensor cable (P/N 467352040) to the hydraulic hose with two cable ties (P/N 506010070). See Figure 8.

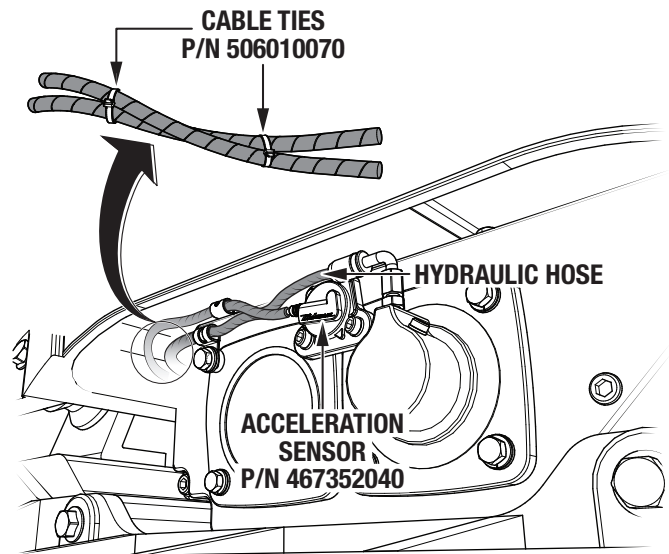

**Figure 8. Cable Tie Placement (Acceleration Sensor and Hydraulic Hose)**

## SENSOR PANEL INSTALLATION

1. If necessary, release the two latches at the top of the rear cover (Figure 9), then pull the rear cover downward to open.

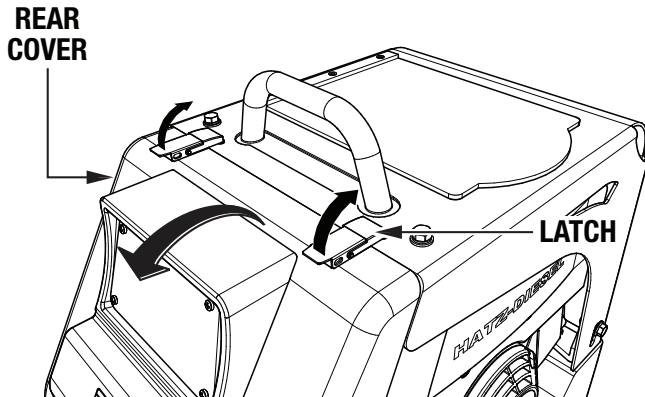

Figure 9. Open Rear Cover

2. Remove the four 6 mm bolts, nuts, and washers securing the rear cover panel to the rear cover, and set them aside (Figure 10). Discard the rear cover panel.

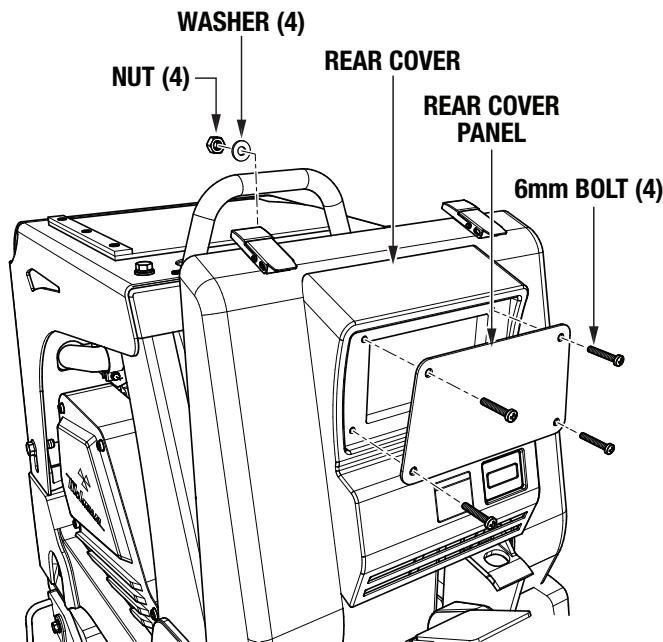

Figure 10. Rear Cover Panel Removal

3. Place the sensor panel backing (P/N 464350510) onto the back of the sensor panel (P/N 467310010 [MVH308DZ], P/N 468310010 [MVH408DZ], or P/N 469310010 [MVH508DZ]). See Figure 11.

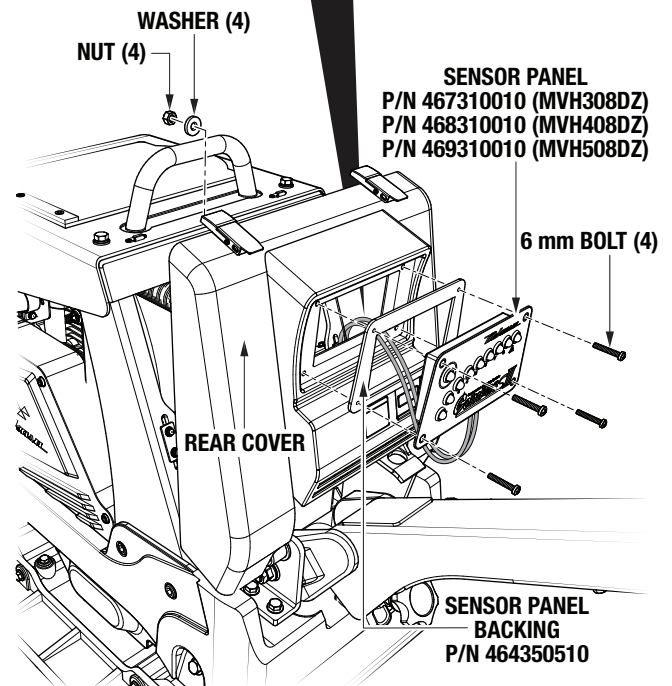
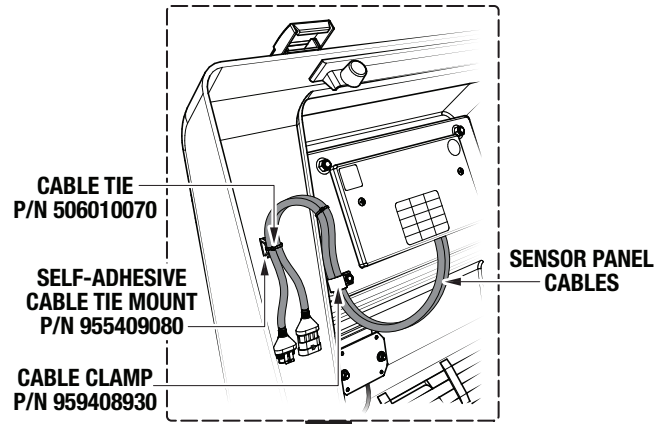
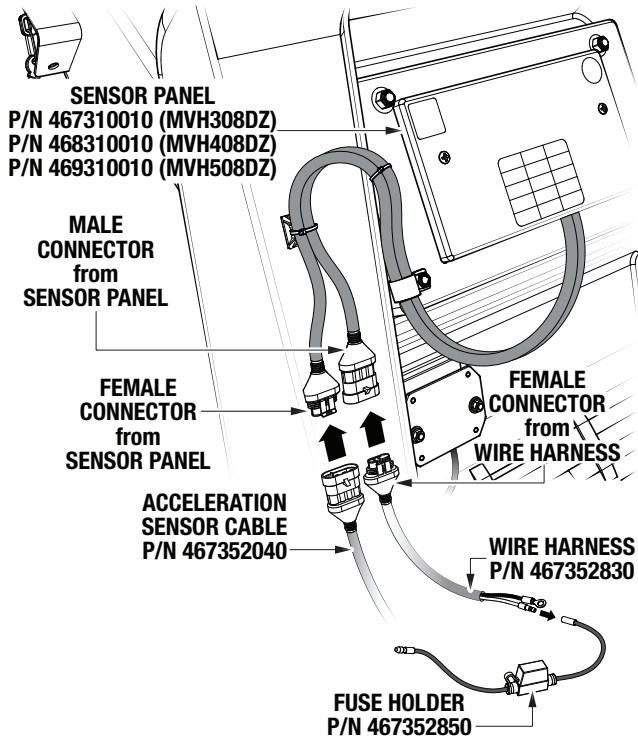

Figure 11. Sensor Panel Installation

4. Place the sensor panel into the open space in the rear cover (Figure 11).
5. Place the large cable clamp (P/N 959408930) onto the two cables extending from the back of the sensor panel. See Figure 11.
6. Secure the sensor panel to the rear cover with the four 6 mm bolts, nuts, and washers that were removed earlier (Figure 11). **MAKE SURE** the cable clamp (P/N 959408930) is secured to the inside of the rear cover with a 6 mm bolt as shown.
7. Secure the sensor panel cables to the inside of the rear cover with a cable tie (P/N 506010070) and the self-adhesive cable tie mount (P/N 955409080). See Figure 11.

## SENSOR CABLE CONNECTIONS

1. Route the acceleration sensor cable (P/N 467352040) through the inside of the plate compactor up toward the sensor panel (P/N 467310010 [MVH308DZ], P/N 468310010 [MVH408DZ], or P/N 469310010 [MVH508DZ]). See Figure 12.



**Figure 12. Sensor Cable Connections**

2. Connect the free end of the acceleration sensor cable (P/N 467352040) to the female connector extending from the sensor panel. See Figure 12.
3. Connect the male connector extending from the sensor panel to the female connector on the wire harness (P/N 467352830). See Figure 12.
4. Connect the male end of the wire harness (P/N 467352830) to the female end of the fuse holder (P/N 467352850). See Figure 12.

## ELECTRICAL WIRING AND ROUTING (MVH308DZ/MVH408DZ ONLY)

The following section describes how to connect and route the COMPAS II electrical wiring components for plate compactor models MVH308DZ and MVH408DZ **only**.

**If installing the compaction sensor on an MVH508DZ compactor, skip this section and proceed to the ELECTRICAL WIRING AND ROUTING (MVH508DZ) section.**

1. Cut and discard the cable ties from the existing wire harness (Figure 13).

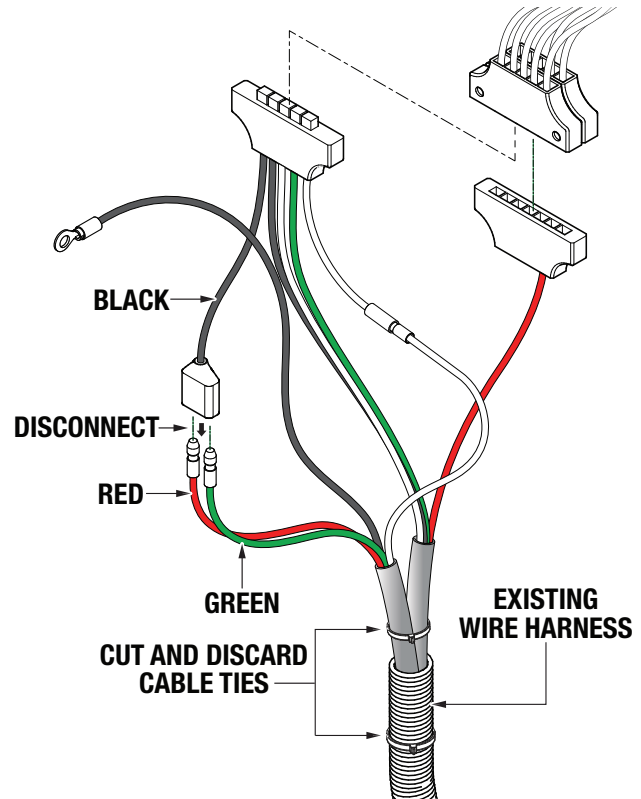

**Figure 13. Existing Wiring Disconnection (MVH308DZ/MVH408DZ)**

2. Locate the electrical connector that has a red wire and a green wire on one end, and a black wire on the other end (Figure 13). Disconnect the red and green wires.

3. Connect the disconnected red and green wires to the female, 2-pin end of the yellow lead wire (P/N 515450380). See Figure 14.

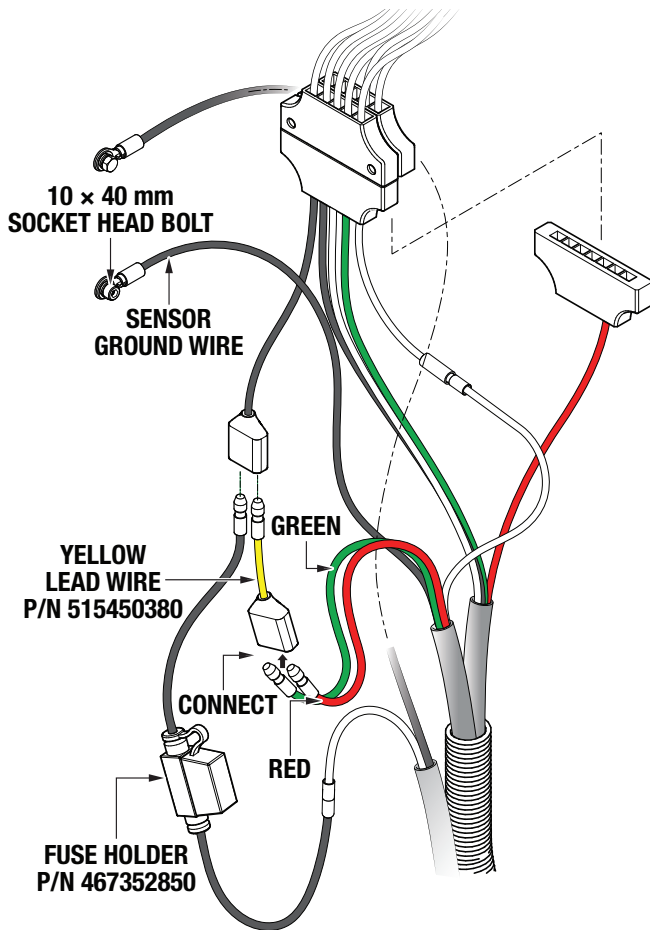

**Figure 14. Wiring Connections  
(MVH308DZ/MVH408DZ)**

4. Connect the free, male end of the yellow lead wire (P/N 515450380) to either of the open, female ports on the connector from which the red and green wires were just removed. See Figure 14.
5. Connect the free, male end of the fuse holder (P/N 467352850) to the remaining available port on the connector from which the red and green wires were just removed. See Figure 14.

6. Secure the sensor ground wire to the frame with the existing 10 x 40 mm socket head bolt shown in Figure 15.

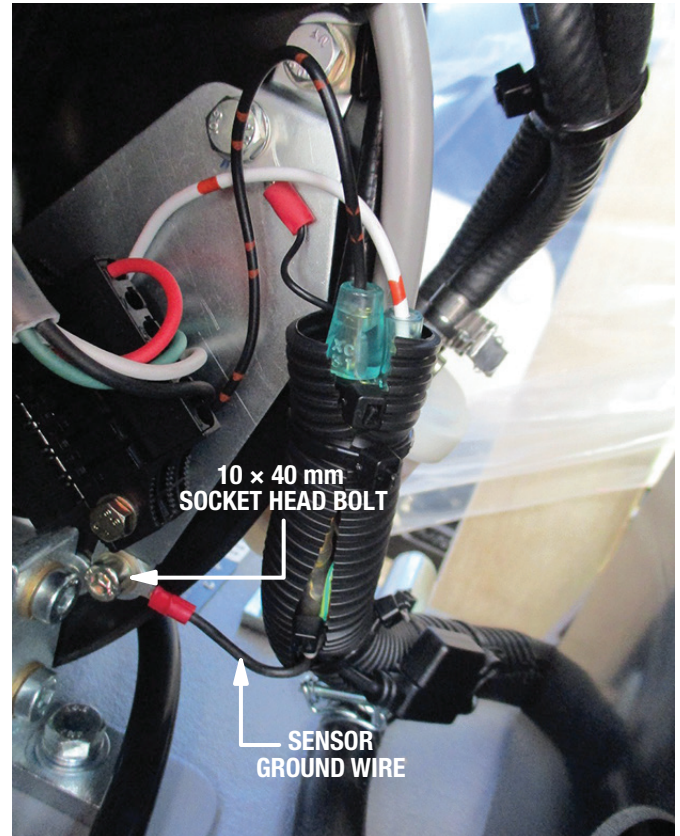

**Figure 15. Ground Wire Connection  
(MVH308DZ/MVH408DZ)**

7. Conceal the new wiring assembly inside the existing wire harness, and secure it with cable ties (P/N 506010070). See Figure 16.

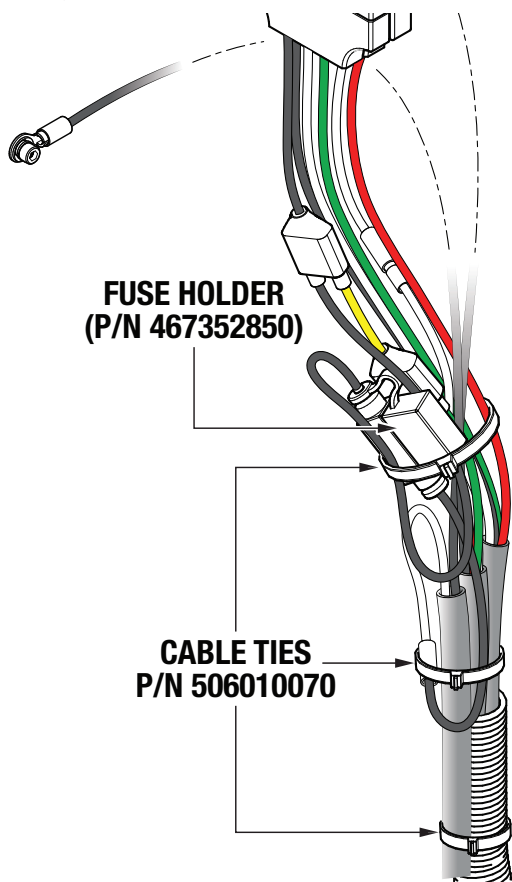

**Figure 16. Conceal and Secure Wiring (MVH308DZ/MVH408DZ)**

8. Secure the fuse holder (P/N 467352850) to the existing wire harness with cable ties (P/N 506010070). See Figure 16.
9. Use any remaining cable ties (P/N 506010070) to further secure cables and wires as needed.

## ELECTRICAL WIRING AND ROUTING (MVH508DZ ONLY)

The following section describes how to connect and route the COMPAS II electrical wiring components for plate compactor model MVH508DZ only.

If installing the compaction sensor on an MVH308DZ or MVH408DZ compactor, skip this section and proceed to the **FINAL ASSEMBLY** section.

1. Remove and set aside the four 14 × 35 mm bolts securing the front cover to the compactor (Figure 17). Remove the front cover and set it aside.

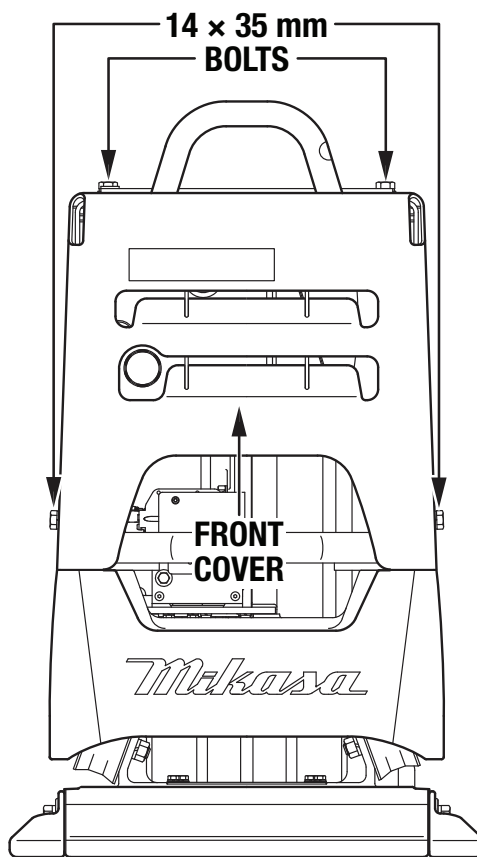

**Figure 17. Front Cover Removal (MVH508DZ)**



- Remove and set aside the four 12 × 55 mm socket head bolts securing the side cover to the compactor (Figure 18). Remove the side cover and set it aside.

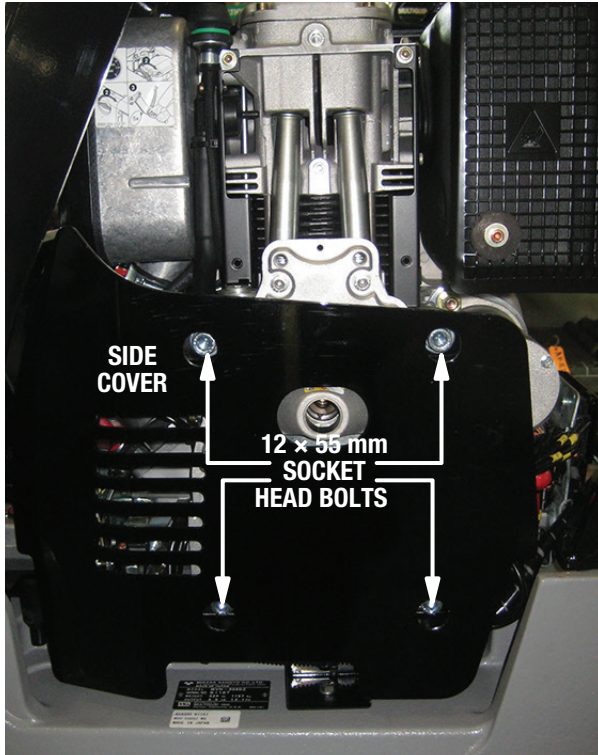

**Figure 18. Side Cover Removal (MVH508DZ)**

- Remove and set aside the two 14 × 35 mm socket head bolts securing the front bumper to the compactor (Figure 19). Remove the front bumper and set it aside.

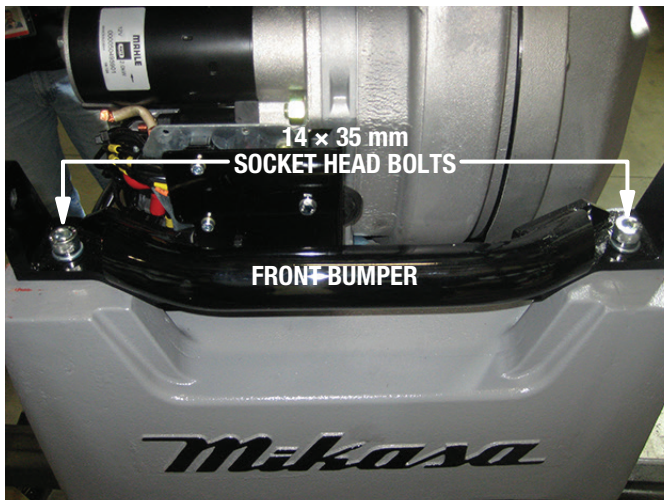

**Figure 19. Front Bumper Removal (MVH508DZ)**

- Remove and set aside the 6 mm bolt and two 5 mm socket head bolts securing the small electrical panel to the front of the unit (Figure 20).

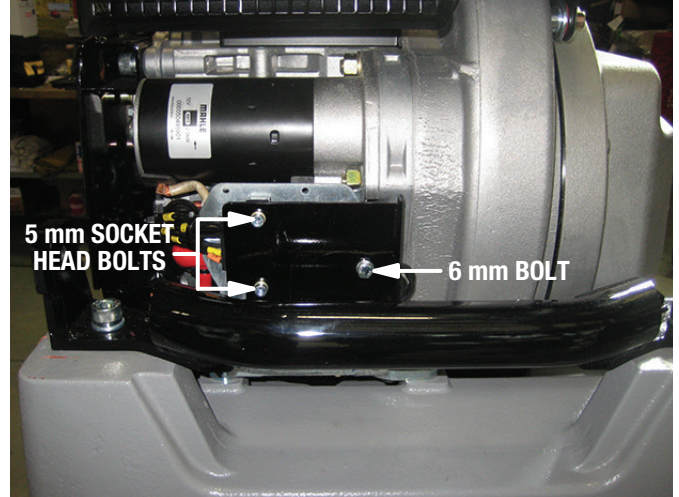

**Figure 20. Electrical Panel Bolt Removal (MVH508DZ)**

- Remove the hex head bolt securing the ground wire to the plate behind the electrical panel (Figure 21).

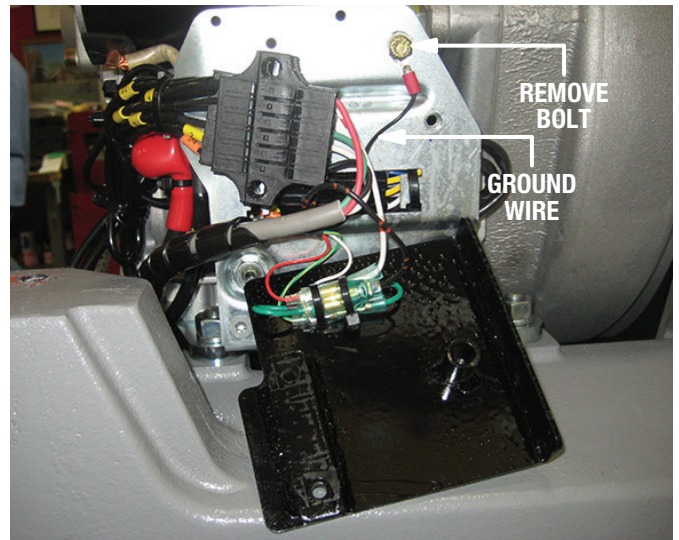

**Figure 21. Ground Wire Disconnection (MVH508DZ)**

6. Cut and discard the cable ties securing the bundled electrical connectors to the back of the electrical panel (Figure 22). Remove the panel and set it aside.

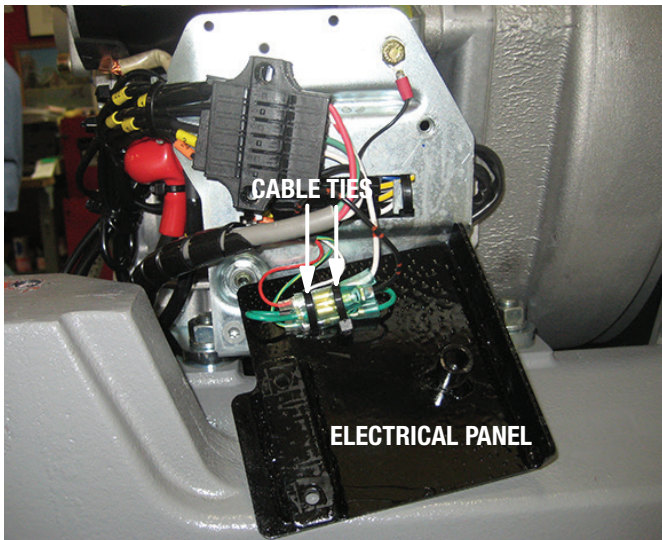

**Figure 22. Cable Tie and Electrical Panel Removal (MVH508DZ)**

7. Locate the electrical connector that has a red wire and a green wire on one side, and a black wire on the other side (Figure 23). Disconnect the red and green wires.

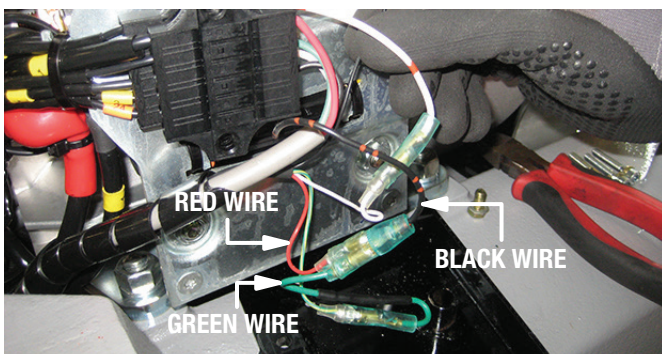

**Figure 23. Existing Wiring Disconnection (MVH508DZ)**

8. Connect the disconnected red and green wires to the female, 2-pin side of the yellow lead wire (P/N 515450380). See Figure 24.

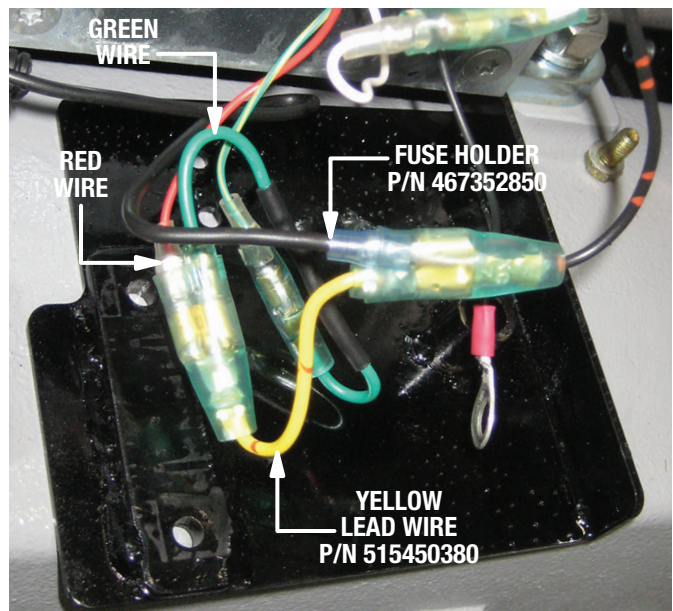

**Figure 24. Wiring Connections (MVH508DZ)**

9. Connect the free, male end of the yellow lead wire (P/N 515450380) to either of the open, female ports on the connector from which the red and green wires were just removed. See Figure 24.
10. Connect the free, male end of the fuse holder (P/N 467352850) to the remaining available port on the connector from which the red and green wires were just removed. See Figure 24.
11. Rebundle the wiring connectors and secure them to the back of the electrical panel with cable ties (P/N 506010070). See Figure 25.

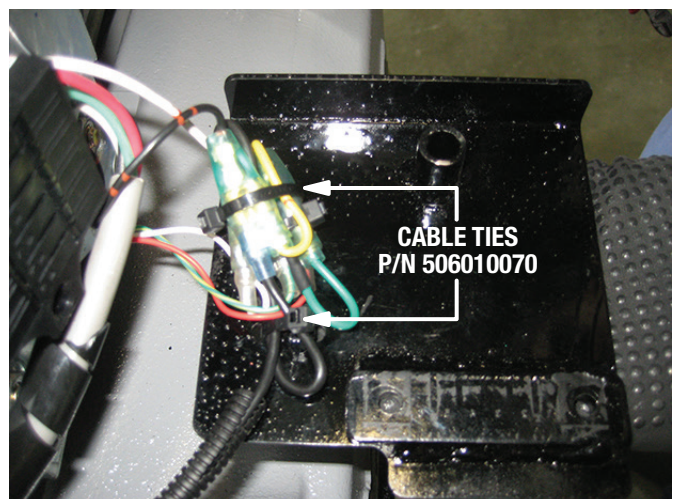

**Figure 25. Secure Wiring to Electrical Panel**

- Secure the electrical panel to the plate behind it with the 6 mm bolt and two 5 mm socket head bolts that were removed earlier (Figure 26). **MAKE SURE** the two existing wiring connectors are secured between the panel and the plate with the 5 mm socket head bolts as shown.

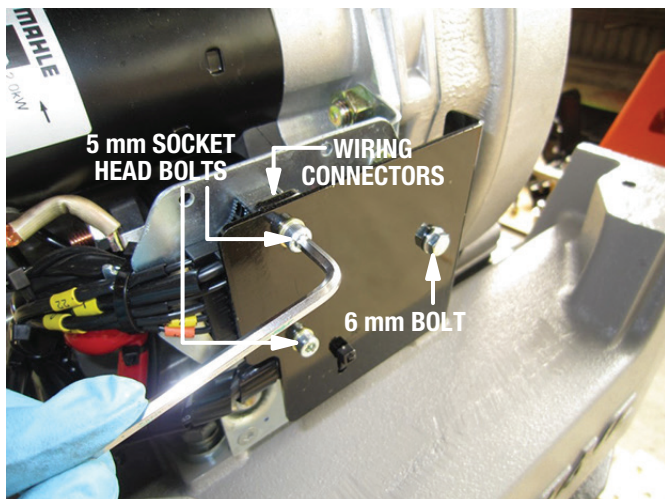

**Figure 26. Electrical Panel Installation**

- Route the sensor wire harness (P/N 467352830) along the right side of the unit as shown in Figure 27, and secure it to the existing wiring with cable ties.

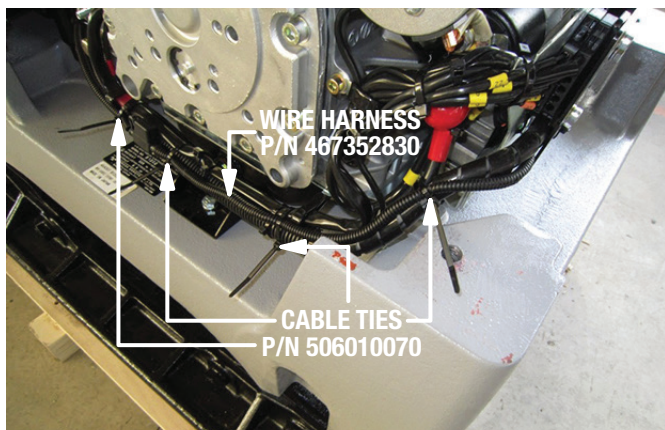

**Figure 27. Route and Secure Wire Harness**

- Secure the sensor ground wire to the frame with the existing socket head bolt as shown in Figure 28.

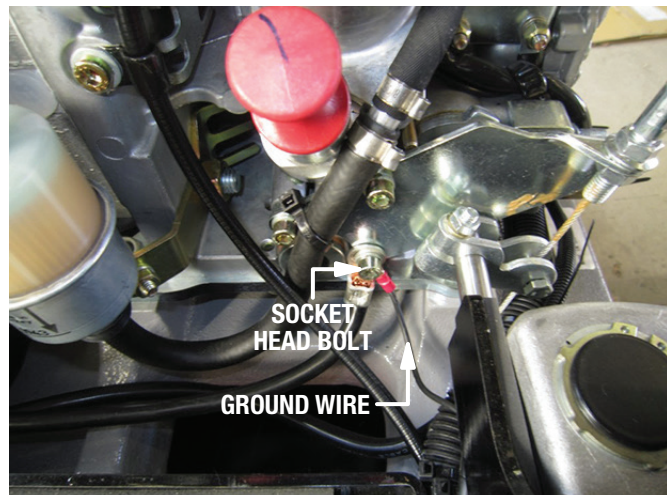

**Figure 28. Ground Wire Connection (MVH508DZ)**

- Apply Loctite® 263™ to the male threads on the two 14 x 35 mm socket head bolts that were removed earlier from the front bumper (Figure 29).

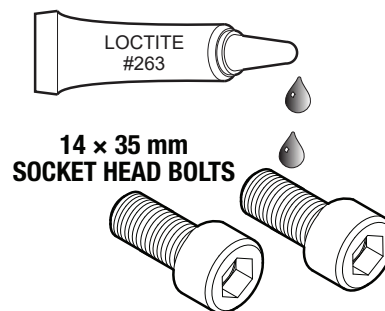

**Figure 29. Applying Loctite® 263™ (Front Bumper Bolts)**

- Secure the front bumper to the compactor with the two 14 x 35 mm socket head bolts that were removed earlier (Figure 30). Torque the bolts to 130 ft-lb (76.6 N·m).

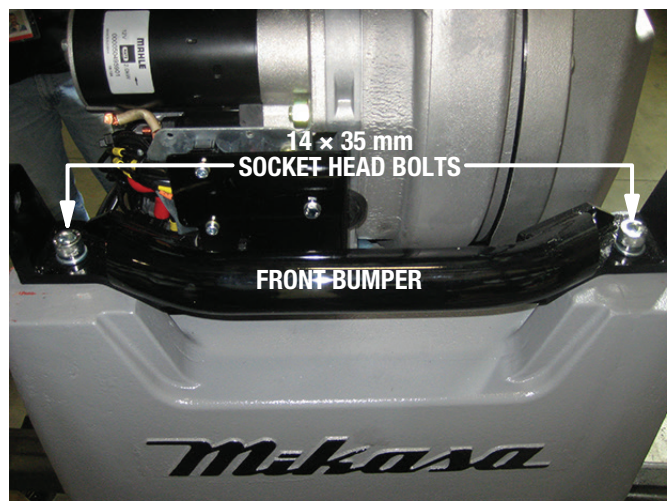

**Figure 30. Front Bumper Installation**

17. Apply Loctite® 243™ to the male threads on the four 12 × 55 mm socket head bolts that were removed earlier from the side cover (Figure 31).

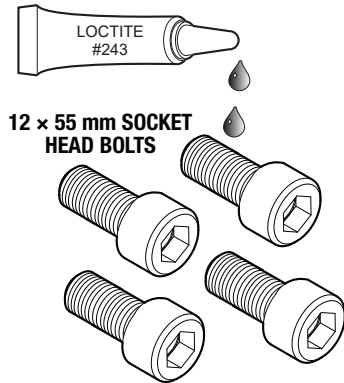

**Figure 31. Applying Loctite® 243™ (Side Cover Bolts)**

18. Secure the side cover to the compactor with the four 12 × 55 mm socket head bolts that were removed earlier (Figure 32). Torque the bolts to 54.2 ft-lb (73.5 N·m).

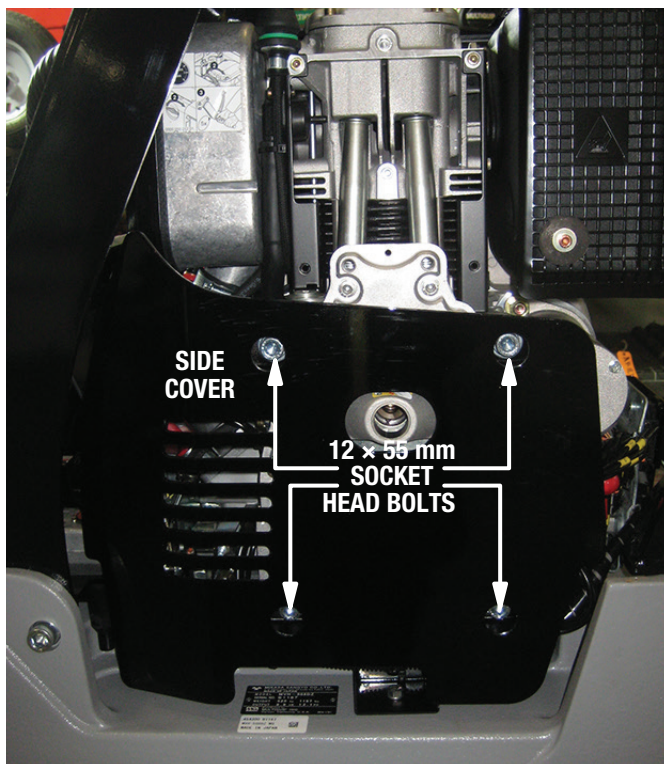

**Figure 32. Side Cover Installation**

19. Apply Loctite® 243™ to the male threads on the four 14 × 35 mm bolts that were removed earlier from the front cover (Figure 33).

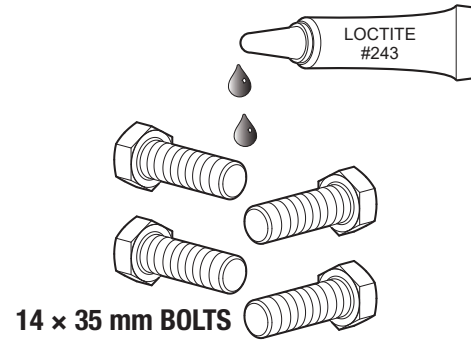

**Figure 33. Applying Loctite® 243™ (Front Cover Bolts)**

20. Secure the front cover to the compactor with the four 14 × 35 mm bolts that were removed earlier (Figure 34). Torque the fastening bolts to 130.2 ft-lb (176.6 N·m).

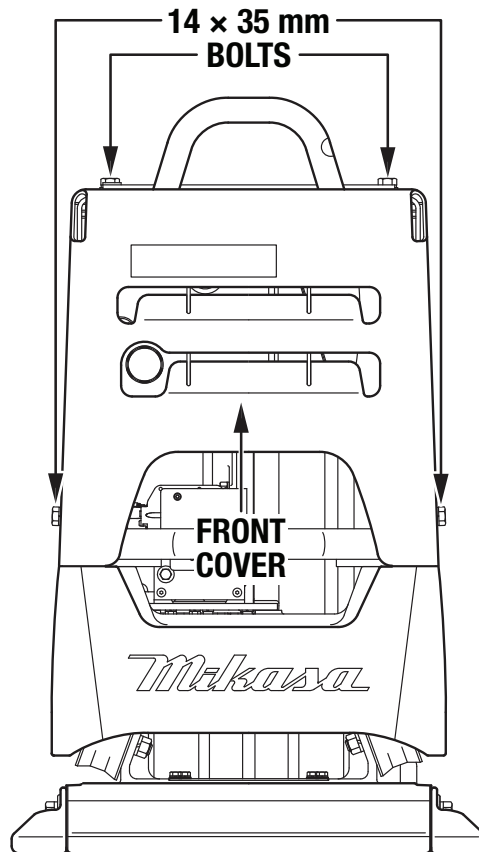

**Figure 34. Front Cover Installation**

## FINAL ASSEMBLY

1. **MAKE SURE** the rear cover will close without pinching or cutting any wires, but leave the rear cover open at this time.
2. Reinstall the battery. **BE SURE** to connect the positive (**RED**) battery cable first, then connect the negative (**BLACK**) battery cable.
3. Loosen the four 8 × 25 mm bolts securing the air cleaner stay to the frame. Slide the air cleaner stay downward to its original position, then tighten the four bolts securely.
4. Close the rear cover and secure it with the two latches (Figure 35).

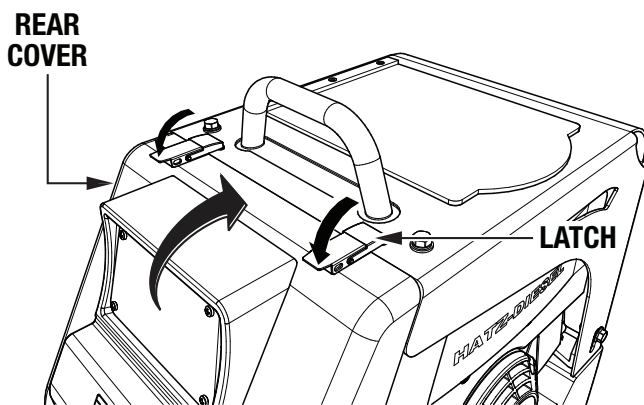

Figure 35. Close Rear Cover

5. Carefully remove the backing from the High Pressure Wash Prohibited decal (P/N 920112220). See Figure 36.

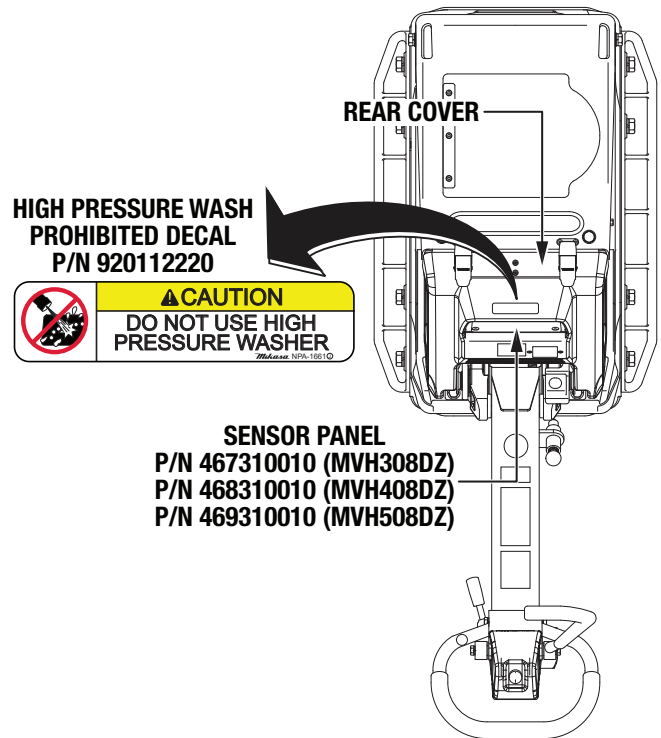

Figure 36. Decal Placement

6. Place the High Pressure Wash Prohibited decal (P/N 920112220) onto the top of the rear cover, just above the sensor panel (P/N 467310010 [MVH308DZ], P/N 468310010 [MVH408DZ], or P/N 469310010 [MVH508DZ]). **MAKE SURE** the decal is oriented straight and flat. See Figure 36.

## STARTUP

### Electric Start

1. Insert the key into the ignition switch.
2. Move the throttle lever to the **IDLE** position (Figure 37).

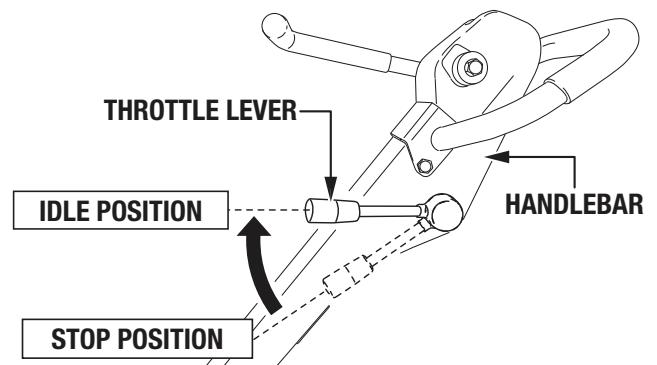
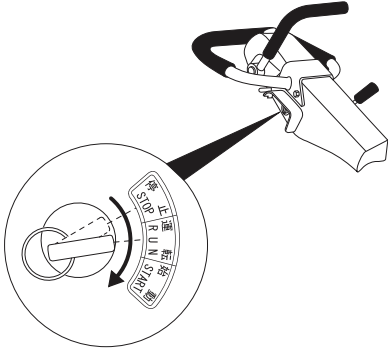

Figure 37. Throttle Lever (IDLE)

- Turn the key **clockwise** to the **RUN** position (Figure 38). The buzzer will begin to sound.



**Figure 38. Ignition Switch (RUN)**

- After “HA” is initially displayed on the tachometer/hour meter, the meter will change to display **cumulative time** (Figure 39).

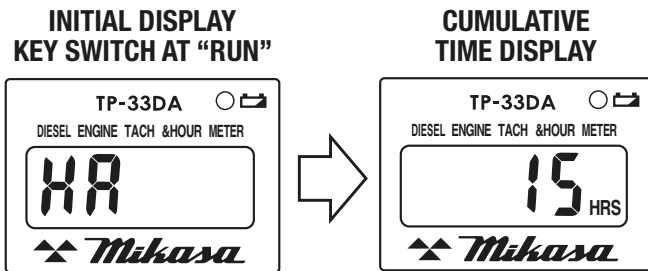

**Figure 39. Tachometer/Hour Meter (Cumulative Time)**

- Turn the key further **clockwise** to the **START** position (Figure 40). Once the engine starts, release the key. As the engine speed increases, the buzzer will stop.

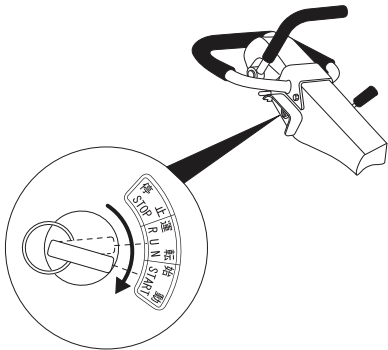

**Figure 40. Ignition Switch (START)**

**CAUTION**

**DO NOT** hold the key in the **START** position for more than 5 seconds. If the engine does not start, move the key back to the **RUN** position, wait about 10 seconds, then try again to start.

**NEVER** turn the ignition switch to the **START** position while the engine is already running.

- Once the engine starts running, the tachometer/hour meter will display **rotational speed (RPM)**. See Figure 41.

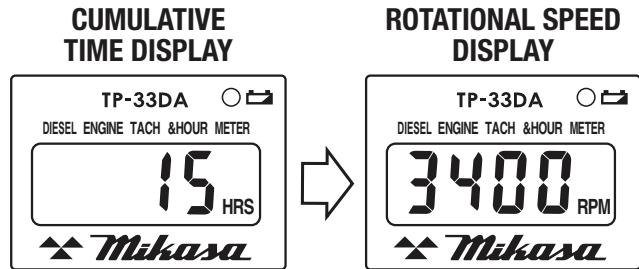
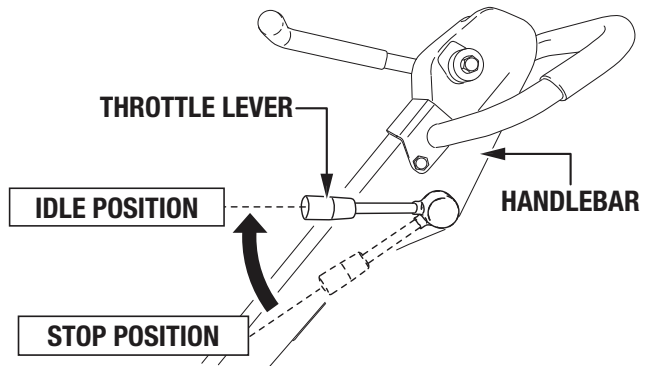

**Figure 41. Tachometer/Hour Meter (Rotational Speed)**

- Idle for 2 to 3 minutes to warm up the engine.

**Recoil Start**

- Insert the key into the ignition switch.
- Move the throttle lever to the **IDLE** position (Figure 42).



**Figure 42. Throttle Lever (IDLE)**

- Turn the key **clockwise** to the **RUN** position (Figure 43). The buzzer will begin to sound.

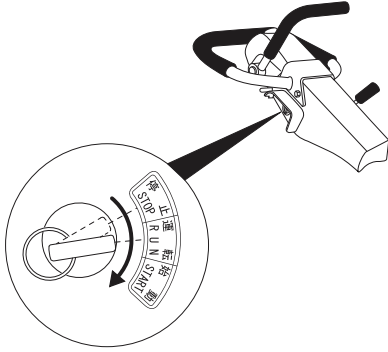

**Figure 43. Ignition Switch (RUN)**

- After “HA” is initially displayed on the tachometer/hour meter, the meter will change to display **cumulative time** (Figure 44).

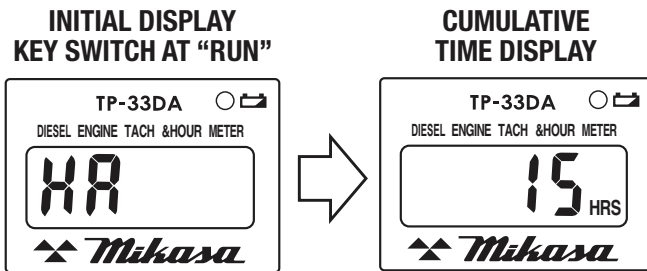

**Figure 44. Tachometer/Hour Meter (Cumulative Time)**

- Slowly pull the recoil starter grip (Figure 45) until resistance is felt, then pull briskly and smoothly to start the engine. Once the engine starts, **DO NOT** release the starter grip immediately. Allow the starter grip to recoil gently to its original position.

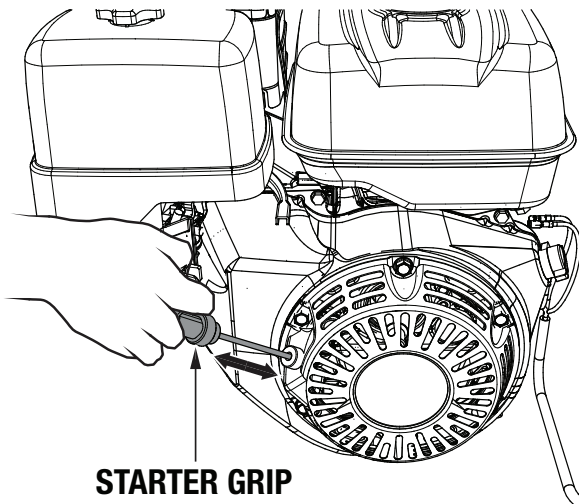

**STARTER GRIP**

**Figure 45. Recoil Starter Grip**

- Idle for 2 to 3 minutes to warm up the engine.

## TESTING

- When the plate compactor is started in **IDLE** mode, the green LED on the sensor panel (P/N 467310010 [MVH308DZ], P/N 468310010 [MVH408DZ], or P/N 469310010 [MVH508DZ]) will flash, and the red LED will turn on. See Figure 46.

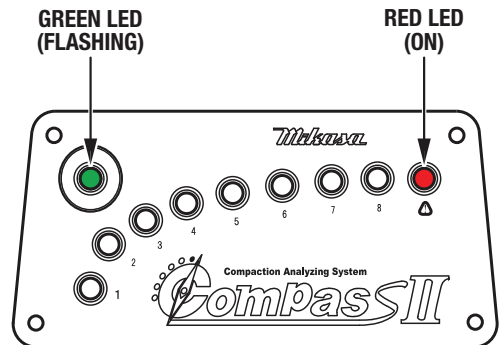

**Figure 46. Sensor Panel Display (IDLE)**

- As engine speed increases and compaction begins, the green LED will stop flashing and turn on (Figure 47). The red LED will turn off, and the first yellow LED (on the left) will turn on.

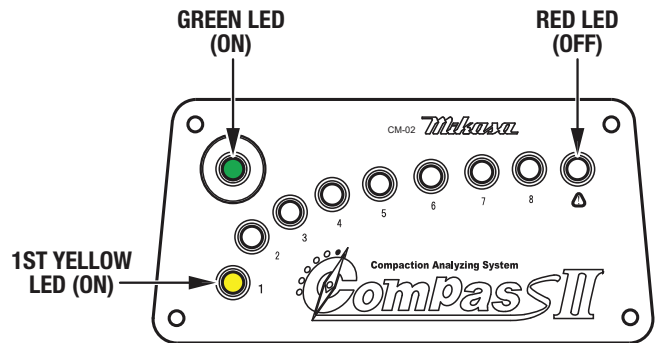

**Figure 47. Sensor Panel Display (Beginning Compaction)**

- As compaction progresses, the rest of the yellow LEDs (2 through 8) will turn on. See Figure 48.

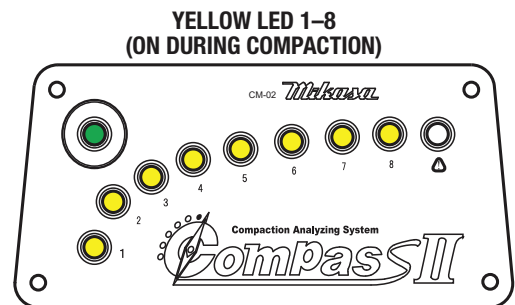

**Figure 48. Sensor Panel Display (Compaction Progression)**

- When the compaction limit is reached, the red LED will turn on (Figure 49). This will only happen **after** all eight yellow LEDs have turned on.

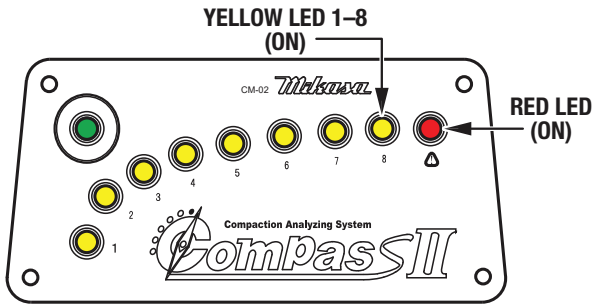

**Figure 49. Sensor Panel Display (Compaction Limit)**

- Once the red LED is lit, the machine cannot compact any further. If the compaction results are unsatisfactory, make sure the soil type, moisture content, lift, and number of passes are appropriate for this machine.

## TROUBLESHOOTING

### Detection of Unstable or Soft Ground

This plate compactor is **not suitable for use on unstable or soft ground** (soil containing high clay content). These ground conditions will cause the green and red LEDs to turn on (Figure 50), and the desired compaction results will be difficult to achieve. Check to make sure the soil to be compacted is prepared to specification before proceeding with the compaction process.

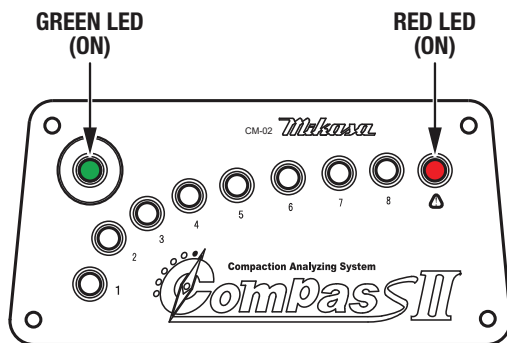

**Figure 50. Unstable or Soft Ground Detection**

### Detection of Vibrational Abnormality

If the V-belt is tensioned incorrectly, improper engine rotational speed will prevent the compactor from achieving the appropriate vibrational frequency. When this occurs, the green LED will flash (Figure 51). Check engine speed and V-belt tension before proceeding with compaction.

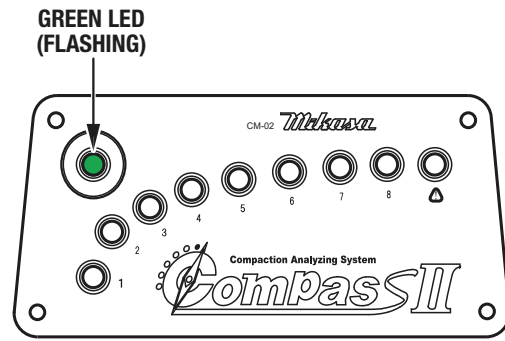
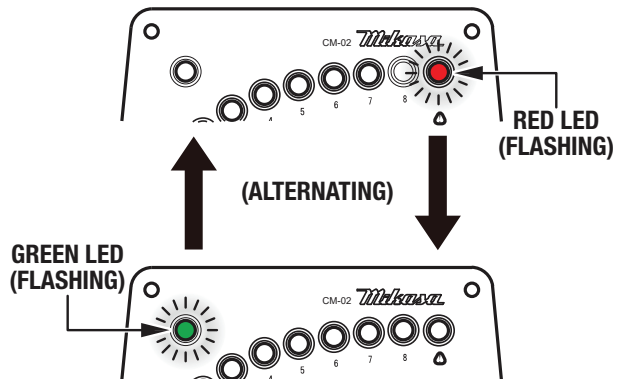

**Figure 51. Vibrational Abnormality Detection**

### Detection of Electrical System Abnormalities

#### *Sensor Cable Connection Failure (Between Acceleration Sensor and Sensor Panel)*

A connection failure between the acceleration sensor (P/N 467352040) and the sensor panel (P/N 467310010 [MVH308DZ], P/N 468310010 [MVH408DZ], or P/N 469310010 [MVH508DZ]) will cause the red and green LEDs to flash alternately as shown in Figure 52. Check the electrical connection between the sensor and the panel before proceeding with compaction.



**Figure 52. Sensor Cable Connection Failure**

#### *Power Cable Connection Failure (Between Battery and Sensor Panel)*

A connection failure between the battery and the sensor panel will prevent any LEDs from flashing or turning on when the plate compactor is started. If the panel LEDs remain unlit upon startup, check the electrical connection between the battery and the sensor panel before proceeding with compaction.



# WIRING DIAGRAM

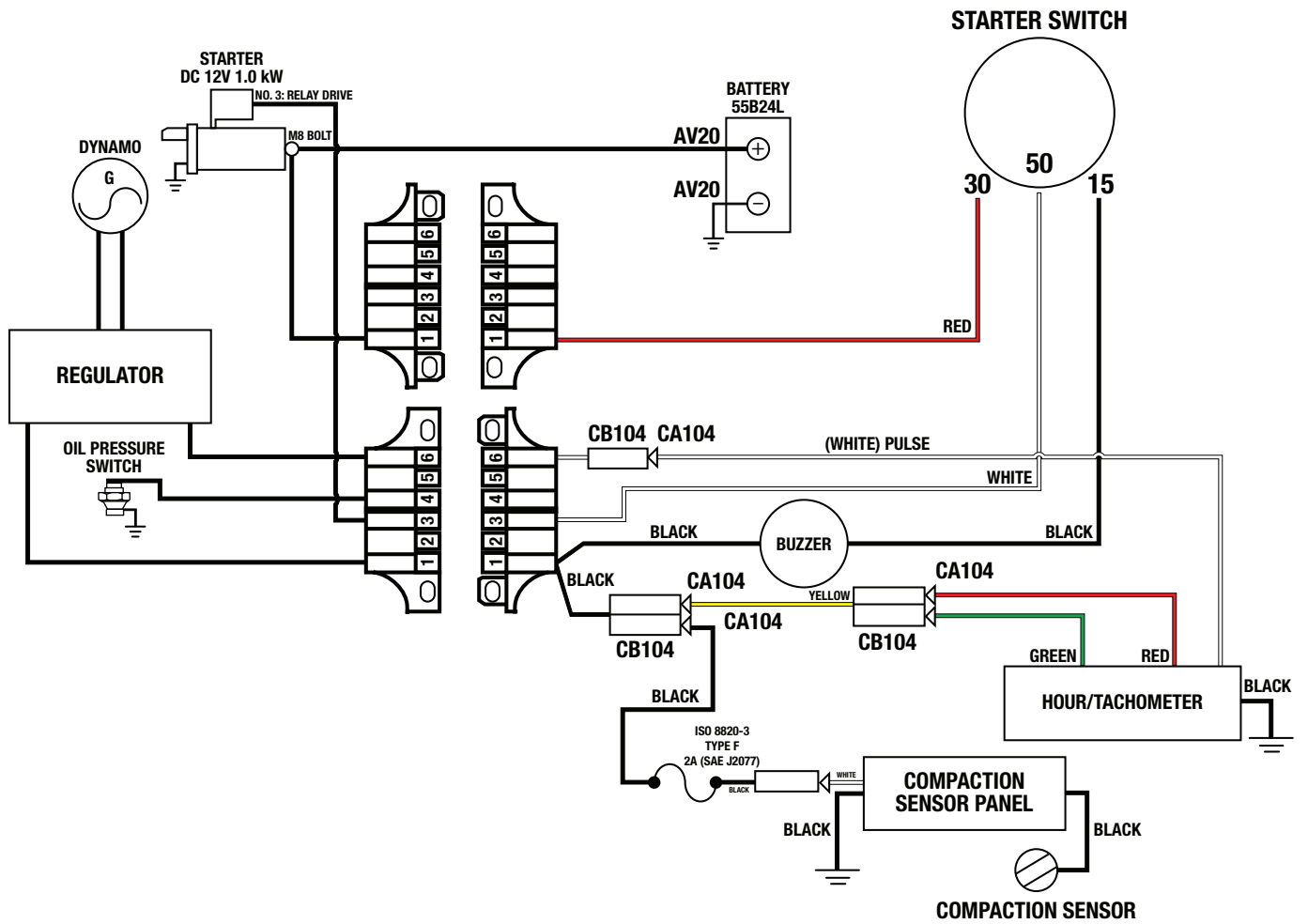

Figure 53. Compaction Sensor Wiring Diagram (Hatz Engine)



# MVH308DZ/MVH408DZ/MVH508DZ Reversible Plate Compactor COMPAS II Compaction Analyzing System Installation Instructions

## HERE'S HOW TO GET HELP

PLEASE HAVE THE MODEL AND SERIAL  
NUMBER ON-HAND WHEN CALLING

### UNITED STATES

#### *Multiquip Corporate Office*

18910 Wilmington Ave. Tel. (800) 421-1244  
Carson, CA 90746 Fax (310) 537-3927  
Contact: mq@multiquip.com

#### *Service Department*

800-421-1244  
310-537-3700

#### *Technical Assistance*

800-478-1244 Fax: 310-943-2238

#### *MQ Parts Department*

800-427-1244 Fax: 800-672-7877  
310-537-3700

#### *Warranty Department*

800-421-1244 Fax: 310-943-2249  
310-537-3700

### CANADA

#### *Multiquip*

4110 Industriel Boul.  
Laval, Quebec, Canada H7L 6V3  
Contact: infocanda@multiquip.com

Tel: (450) 625-2244  
Tel: (877) 963-4411  
Fax: (450) 625-8664

### UNITED KINGDOM

#### *Multiquip (UK) Limited Head Office*

Unit 2, Northpoint Industrial Estate, Tel: 0161 339 2223  
Globe Lane, Fax: 0161 339 3226  
Dukinfield, Cheshire SK16 4UJ  
Contact: sales@multiquip.co.uk

© COPYRIGHT 2017, MULTIQUIP INC.

Multiquip Inc and the MQ logo are registered trademarks of Multiquip Inc. and may not be used, reproduced, or altered without written permission. All other trademarks are the property of their respective owners and used with permission.

The information and specifications included in this publication were in effect at the time of approval for printing. Illustrations, descriptions, references and technical data contained in this document are for guidance only and may not be considered as binding. Multiquip Inc. reserves the right to discontinue or change specifications, design or the information published in this publication at any time without notice and without incurring any obligations.

Your Local Dealer is:

